

WATER LEVEL INDICATOR

PRODUCT INFO



Description

For use in water reservoirs to show water level at a glance.

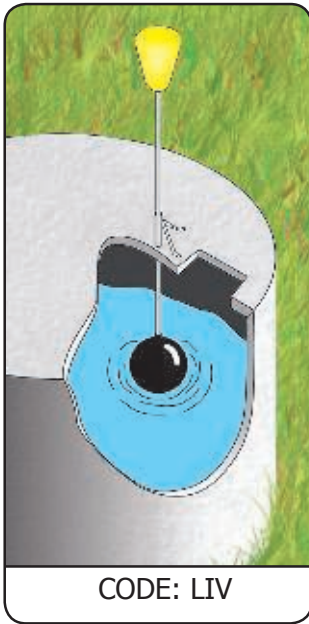

Dimensions

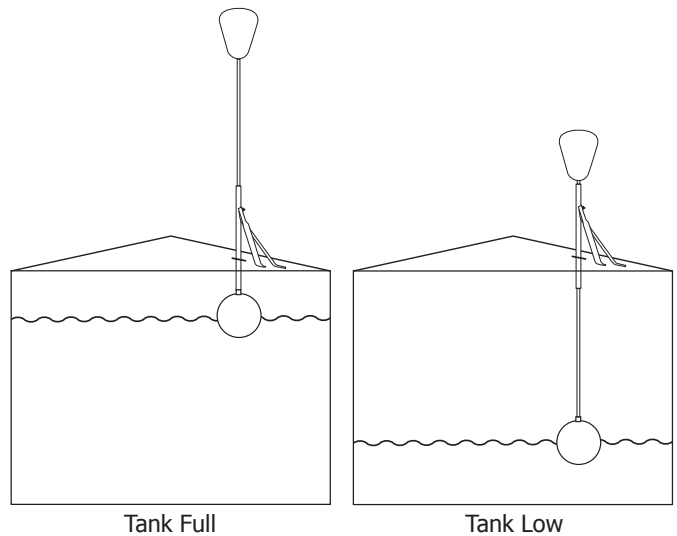
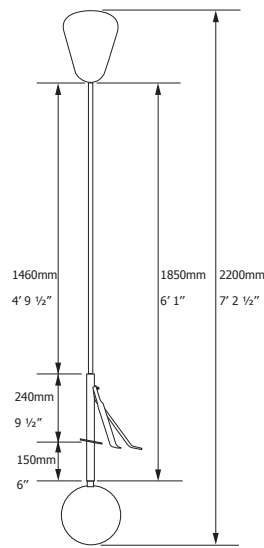

Applications

- Easily fitted to Concrete & Plastic tanks to show water level at a glance

Features

- Highly visible yellow indicator.
- Double bracing arms on mounting bracket.
- Constructed from stainless steel.
- Long stainless steel shaft screws in half for shipping.

Installation

1 Drill 20mm hole in tank, next to man hole.

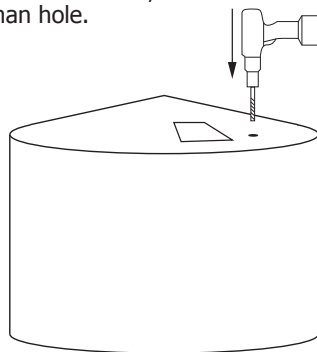

2 Fit Bracket.

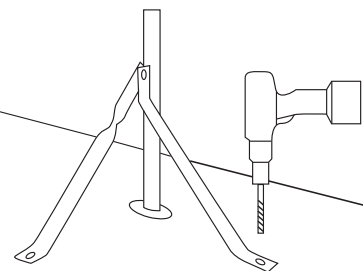

3 Mounting to:

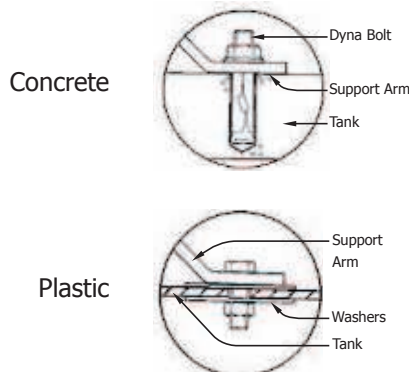

4 Slide in Shaft & Fit ball.

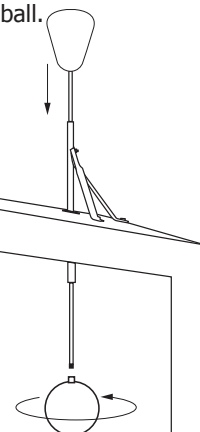

ACCESSORIES